

# DX Series CNC Turning Centers





# Rigid Servo Turret

DX Series machines are equipped with high speed and high precision Bi-directional Servo Turret with hydraulic clamping system achieved by 3-piece hirth coupling. Tool change time is just **0.5 second...**

# Operator Panel

The newly designed Easy-to-Operate operator panel of the machine is made considering the reliability and the operator friendliness.

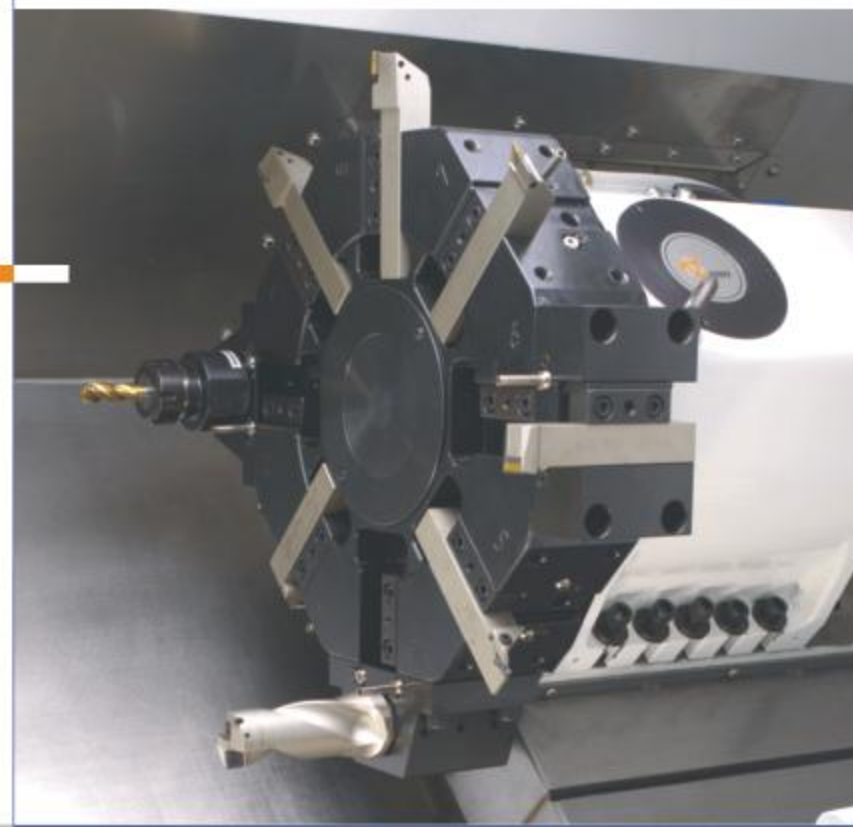

# Power Torque Diagram

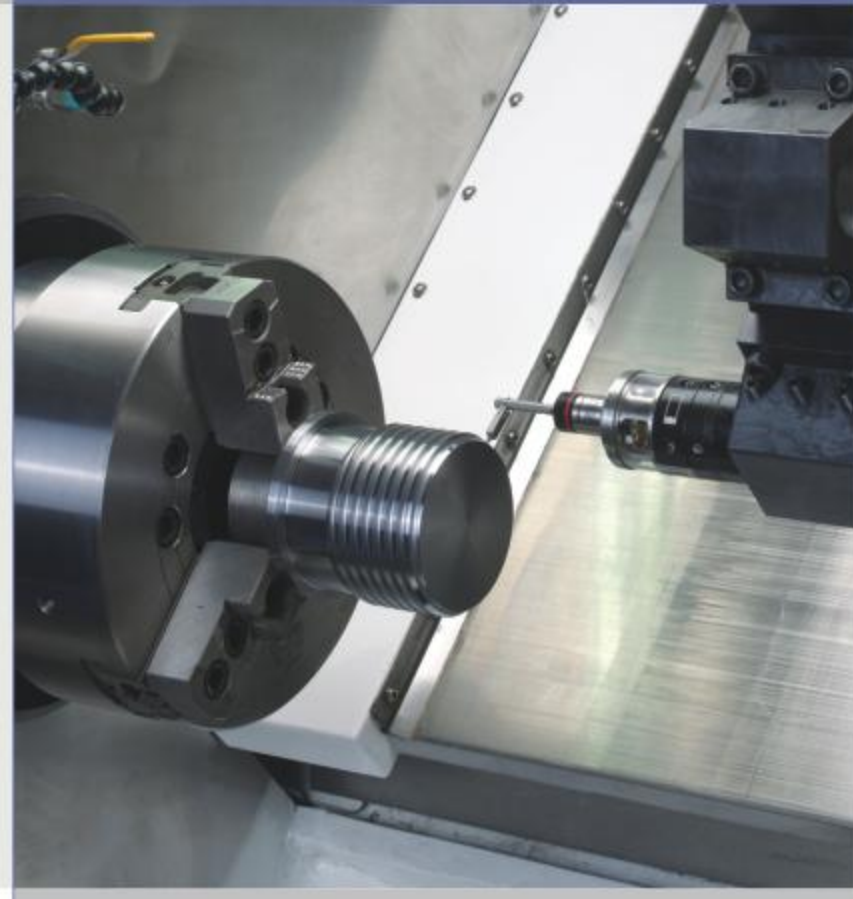
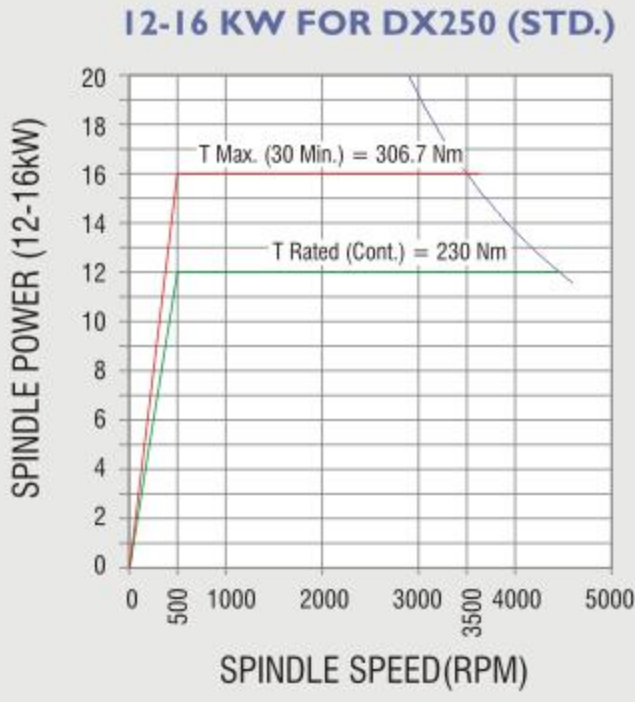

# Machine Range & Tool Interface Diagram for DX-250 / DX-350 with A<sub>2</sub>6 & A<sub>2</sub>8 Spindle Having 80 Center Height Turret \*

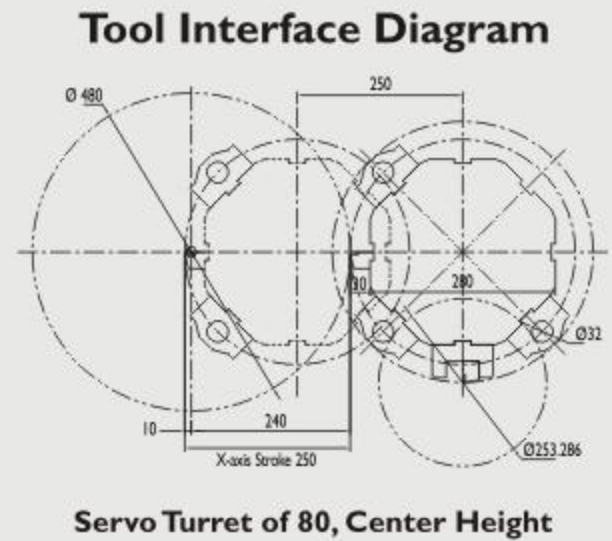
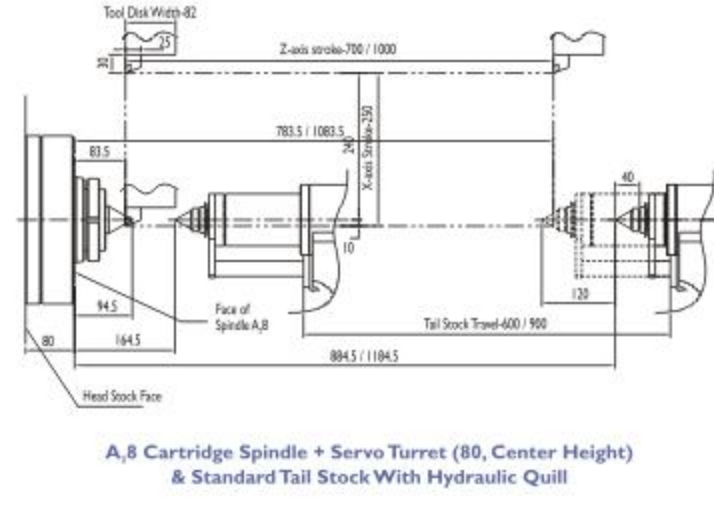
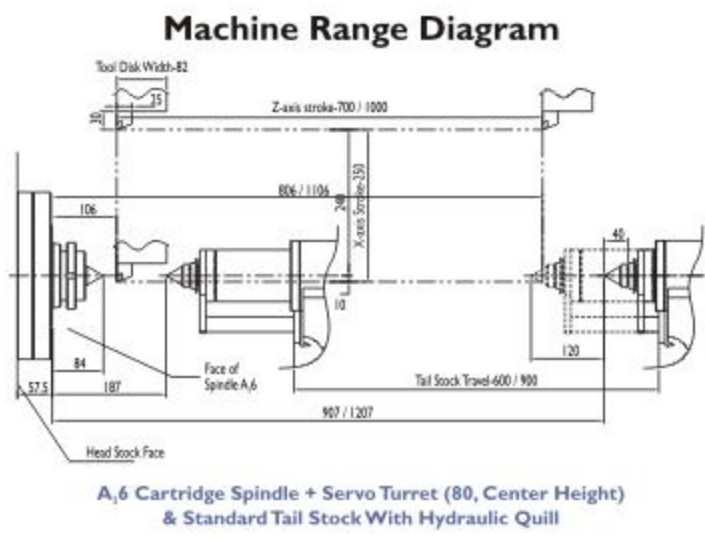

# Machine Range & Tool Interface Diagram for DX-250 / DX-350 with A<sub>2</sub>6 & A<sub>2</sub>8 Spindle Having 100 Center Height Turret \*

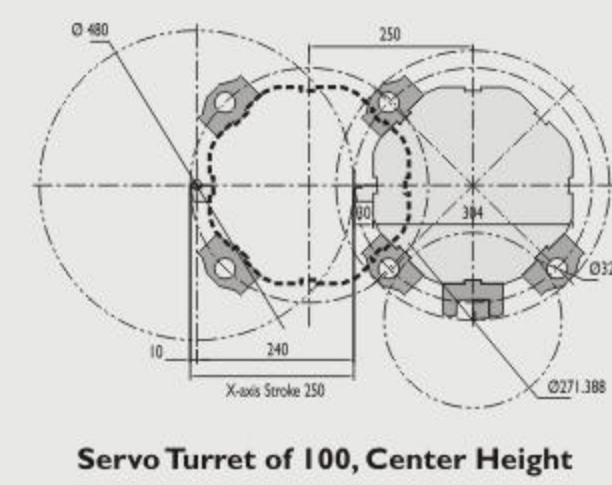
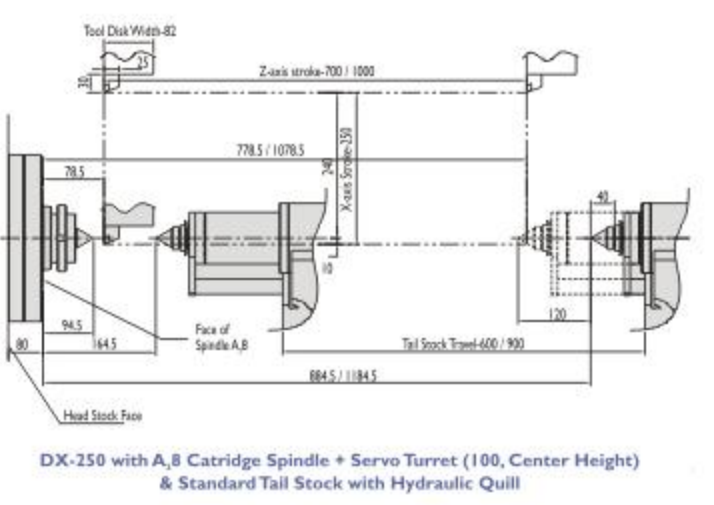
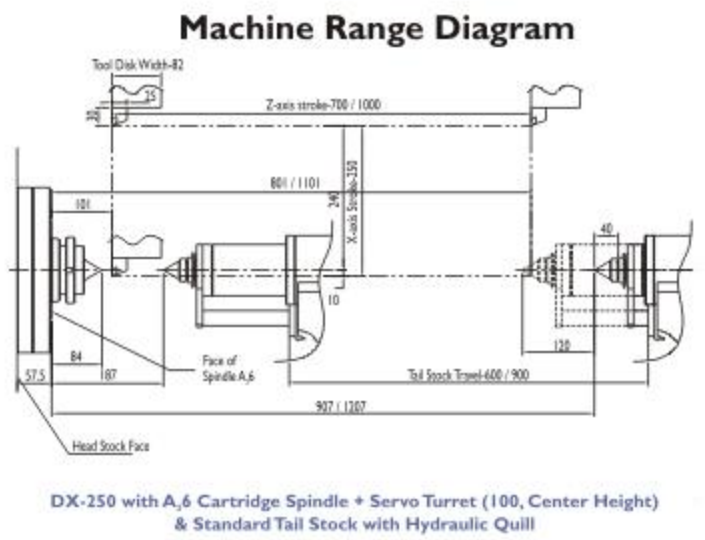

\* Different Tool Interface Diagram for DX-350 (1500 ABC)